

# **HURRICANE™** **1400**

**User Manual**

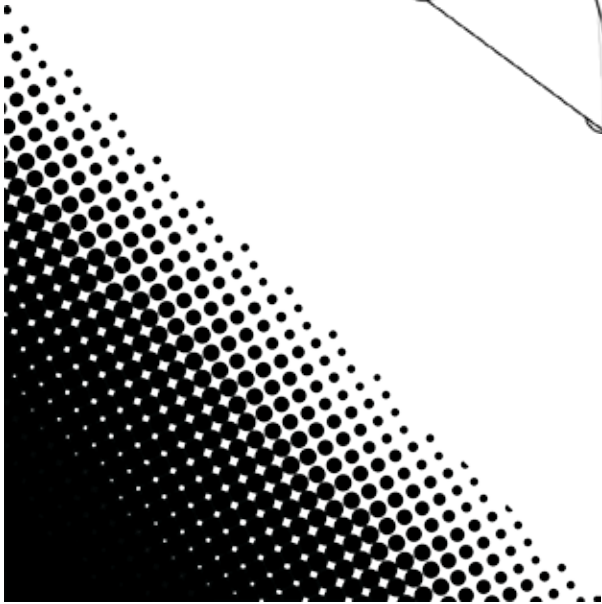
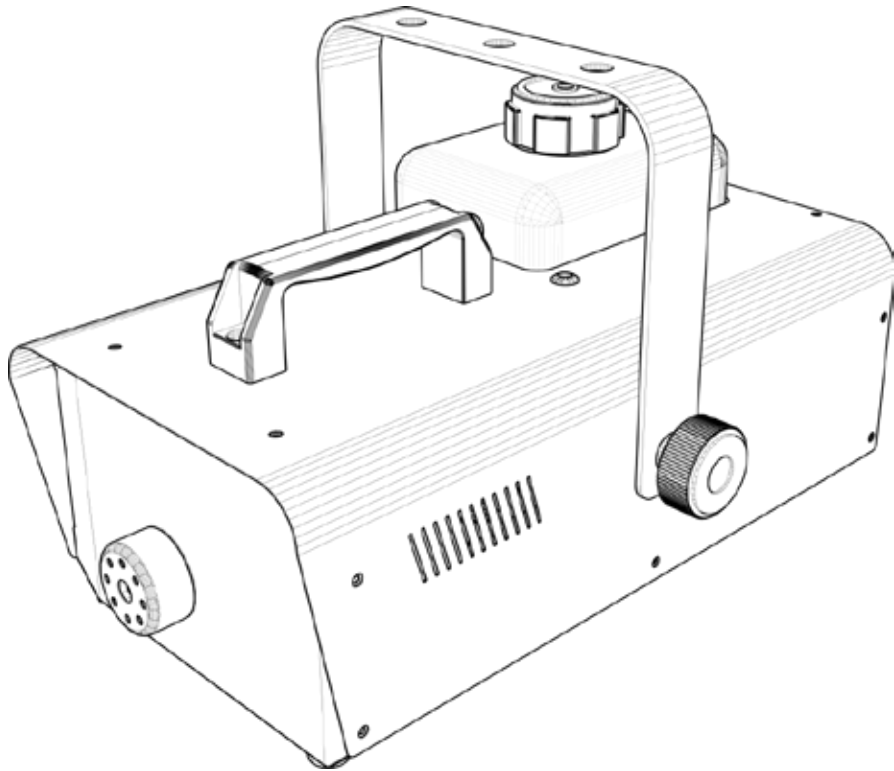

**CHAUVET®**

---

# TABLE OF CONTENTS

<b>1. Before You Begin</b> .....	<b>3</b>
What Is Included.....	3
Unpacking Instructions .....	3
Claims .....	3
Text Conventions .....	3
Symbols.....	3
Disclaimer.....	3
Product at a Glance.....	4
Safety Notes.....	4
<b>2. Introduction</b> .....	<b>5</b>
Overview.....	5
Dimensions.....	6
<b>3. Setup</b> .....	<b>7</b>
AC Power .....	7
Fuse Replacement .....	7
Mounting.....	8
Orientation.....	8
Rigging .....	8
<b>4. Operation</b> .....	<b>9</b>
Remote or Manual Operation .....	9
Wired Timer Controller (FC-T) Setup.....	9
Wired Timer Controller (FC-T) Operation .....	9
Optional Wireless Remote (FC-W) .....	10
Fluid Tank Indicator Lights .....	10
<b>5. Technical Information</b> .....	<b>11</b>
Fogger Maintenance .....	11
Storage .....	11
<b>6. General Troubleshooting</b> .....	<b>12</b>
<b>7. Technical Specifications</b> .....	<b>13</b>
<b>Returns</b> .....	<b>14</b>
<b>Contact Us</b> .....	<b>15</b>

# 1. BEFORE YOU BEGIN

## What Is Included

- Hurricane™ 1400
- FC-T Timer Remote Control
- Hanging Bracket with Mounting Hardware
- Power Cord
- Warranty Card
- Quick Reference Guide

## Unpacking Instructions

Carefully unpack the product immediately and check the container to make sure all the parts are in the package and are in good condition.

## Claims



If the box or the contents (the product and included accessories) appear damaged from shipping, or show signs of mishandling, notify the carrier immediately, not Chauvet. Failure to report damage to the carrier immediately may invalidate your claim. In addition, keep the box and contents for inspection.

For other issues, such as missing components or parts, damage not related to shipping, or concealed damage, file a claim with Chauvet within 7 days of delivery.

## Text Conventions

Convention	Meaning
1—512	A range of values
50/60	A set of values
Settings	A menu option
Menu > Settings	A sequence of menu options
<Enter>	A button

## Symbols

Symbol	Meaning
	Critical installation, configuration, or operation information. Not following these instructions may make the product not work, cause damage to the product, or cause harm to the operator.
	Important installation or configuration information. The product may not function correctly if this information is not used.
	Useful information.

## Disclaimer

The information and specifications contained in this User Manual are subject to change without notice. Chauvet assumes no responsibility or liability for any errors or omissions, and reserves the right to revise or recreate this manual at any time. Download the latest version from [www.chauvetlighting.com](http://www.chauvetlighting.com).

© Copyright 2015 Chauvet. All rights reserved.

Electronically published by Chauvet in the United States of America.

Author	Date	Editor	Date
M. Trouard	07/15/2015	R. Isenstadt	07/16/2015

## Product at a Glance

Use on Dimmer	X	Auto Programs	X
Outdoor Use	X	Fixed voltage (120 V or 230 V)	P
Sound-Activated	X	Replaceable Fuse	P
DMX	X	User-Serviceable	X
Master/Slave	X	Duty Cycle	X

## Safety Notes

These notes include important information about the mounting, usage, and maintenance of this product; read before using the product.



- Always connect the product to a grounded circuit to avoid the risk of electrocution.
- Always disconnect the product from the power source before cleaning or replacing the fuse.
- Make sure the power cord is not crimped or damaged.
- Never disconnect the product from power by pulling or tugging on the cord.
- If mounting the product overhead, always secure to a fastening device using a safety cable.
- Make sure there are no flammable materials close to the product when operating.
- Do not touch the product's housing when operating because it may be very hot.
- Do not mount the product on a flammable surface (linoleum, carpet, wood, paper, carton, plastic, etc.).
- The product's nozzle is very hot during operation and it remains hot for a long time after operation has stopped.
- The fog exits the nozzle at a very high temperature. Keep a minimum distance of 6.5 ft (2 m) from the nozzle to the nearest object.
- Do not use the product as a space heater.
- Do not drink or come in contact with the fog fluid. If you do, call your local emergency service (911 in the US) for help.
- Do not add perfume, alcohol, gasoline, or any other flammables to the fog fluid.



- Always make sure that the voltage of the outlet to which you are connecting the product is within the range stated on the decal or rear panel of the product.
- The product is for indoor use only! (IP20) To prevent risk of fire or shock, do not expose the product to rain or moisture.
- Always install the product in a location with adequate ventilation, at least 20 in (50 cm) from adjacent surfaces.
- Be sure that no ventilation slots on the product's housing are blocked.
- Never connect the product to a dimmer or rheostat.
- Make sure to replace the fuse with another of the same type and rating.
- Never carry the product from the power cord or any moving part. Always use the hanging/mounting bracket.
- The maximum ambient temperature (Ta) is 104 °F (40 °C). Do not operate the product at higher temperatures.
- In the event of a serious operating problem, stop using the product immediately.
- Never try to repair the product. Repairs carried out by unskilled people can lead to damage or malfunction. Contact the nearest authorized technical assistance center.
- This product is not intended for permanent installation.
- Use only CHAUVET® water-based fog fluid.
- Drain the tank before transporting or storing the product.
- To eliminate unnecessary wear and improve its lifespan, during periods of non-use completely disconnect the product from power via breaker or by unplugging it.



Keep this User Manual for future use. If you sell the product to another user, be sure to give this document to the next owner.



FCQ (Fog Cleaner Quart) was specifically developed by Chauvet to clean your Hurricane™ 1400. Make sure you use FCQ regularly, no longer than 90 days between cleanings, to increase the life of your fogger.

# 2. INTRODUCTION

## Overview

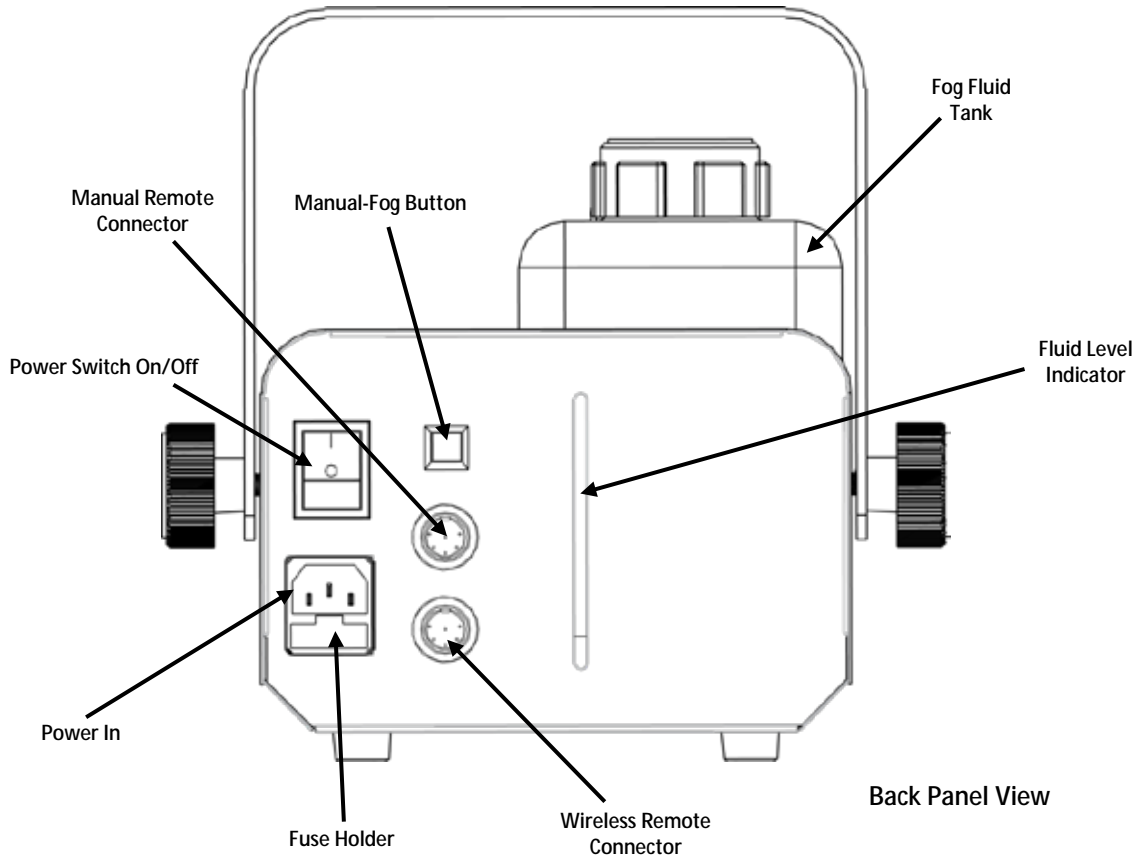

# Dimensions

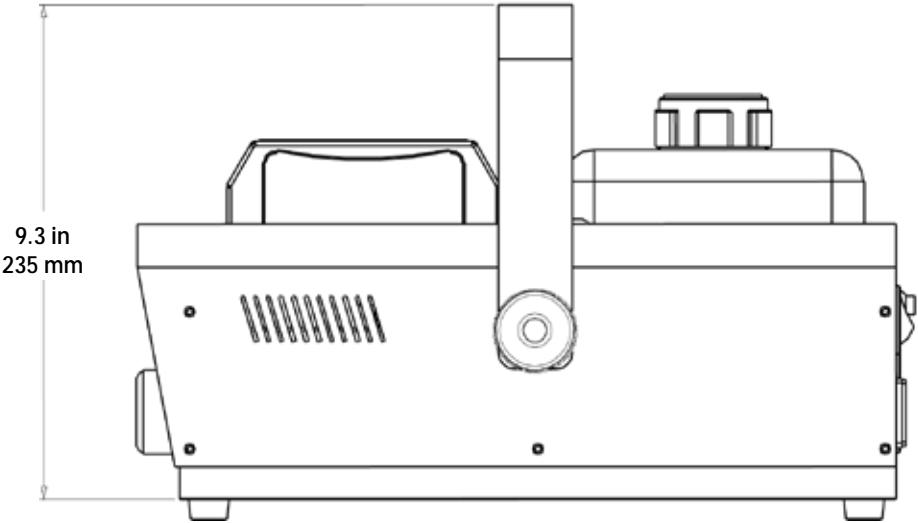
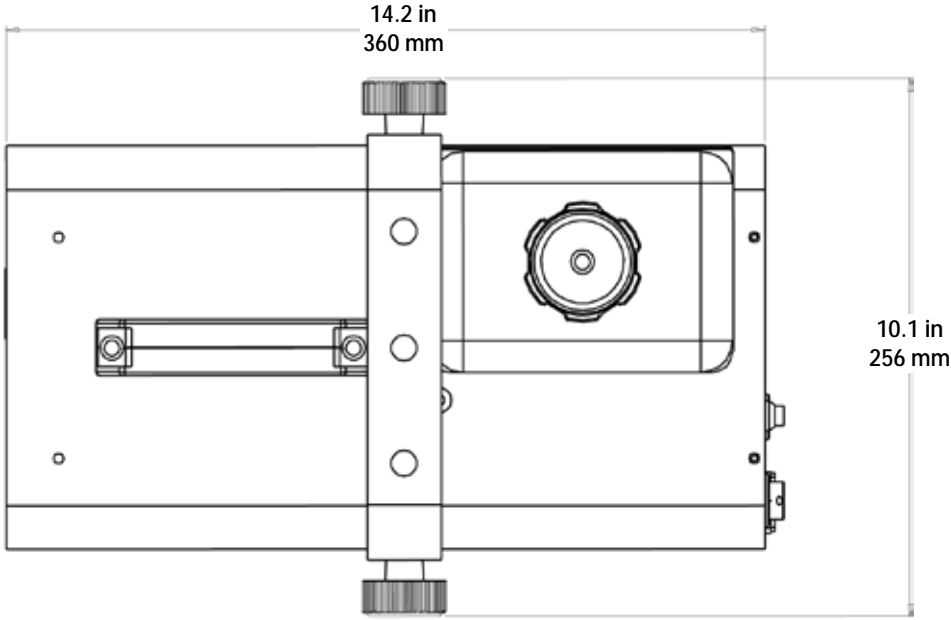

---

## 3. SETUP

**AC Power** This Hurricane™ 1400 has a fixed voltage power supply and it can work with an input voltage of either 120 VAC, 60 Hz or 230 VAC, 50 Hz, depending on the specific model.

To determine the product's power requirements (circuit breaker, power outlet, and wiring), use the current value listed on the label affixed to the product's back panel, or refer to the product's specifications chart. The listed current rating indicates the product's average current draw under normal conditions.



- **Always connect the product to a protected circuit (circuit breaker or fuse). Make sure the product has an appropriate electrical ground to avoid the risk of electrocution or fire.**

- **To eliminate unnecessary wear and improve its lifespan, during periods of non-use completely disconnect the product from power via breaker or by unplugging it.**



- **Never connect the product to a rheostat (variable resistor) or dimmer circuit, even if the rheostat or dimmer channel serves only as a 0 to 100% switch.**

### **Fuse Replacement**

1. Disconnect the product from power.
2. Wedge the tip of a flat-head screwdriver into the slot of the fuse holder.
3. Pry the safety cap out of the housing.
4. Remove the blown fuse from the clip on the front of the safety cap and replace with a fuse of the exact same type and rating.
5. Re-insert the fuse holder and reconnect power.



- **Disconnect the product from power before replacing the fuse.**
- **Always replace a blown fuse with another of the same type and rating.**

**Mounting** Before mounting the product, read and follow the safety recommendations indicated in the [Safety Notes](#).

## Orientation



**This product may NOT be tilted. This product should be level when on a surface or when mounted.**

## Rigging

- Before deciding on a location, always make sure there is easy access to the product for maintenance and fluid replenishment.
- Make sure that the structure or surface onto which you are mounting the product can support the product's weight (see the [Technical Specifications](#)).
- When mounting the product overhead, always use a safety cable. Mount the product securely to a rigging point, such as an elevated platform or a truss.
- When rigging the product onto a truss, you should use a mounting clamp of appropriate weight capacity. The bracket has 13-mm holes, which are appropriate for this purpose.
- The rubber feet also serve as floor supports and allow for surface mounting. When mounting the product on the floor, make sure that the product and cables are away from people and vehicles.

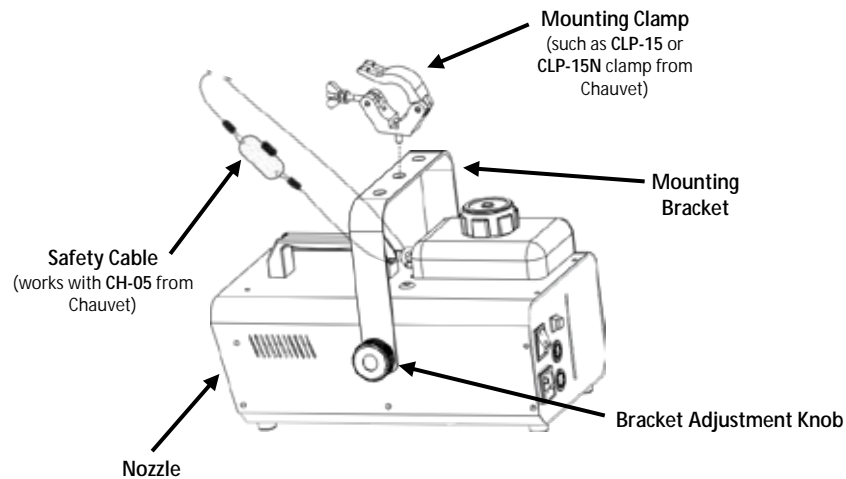

## Mounting Diagram

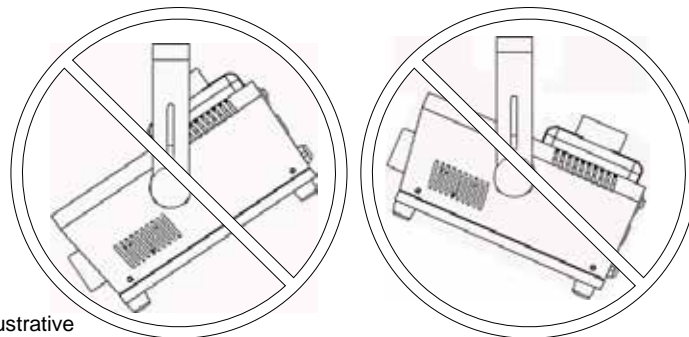

\*For illustrative purposes only



**While operating the Hurricane™ 1400, make sure there is adequate fog fluid in the machine to prevent pump and heater damage. When the fog fluid level becomes low, simply add more fog fluid to continue using the Hurricane™ 1400.**



## 4. OPERATION

### Remote or Manual Operation Wired Timer Controller (FC-T) Setup

The Hurricane™ 1400 can be operated manually, or with the included wired timer controller (FC-T). The Manual <FOG> button is located on the rear of the unit. See the product [Overview](#). Additionally, the product can be operated by the FC-W wireless remote, available separately.

The FC-T wired timer controller allows you to automatically trigger fog output by setting interval and duration times. LED indicator lights display the machine and controller's current state. Rotary knobs set interval time, output, and duration time, while manual and continuous buttons allow overriding control.

1. Plug in the fog machine to power.
2. Plug in the wired timer controller to the Manual Remote Connector socket on the back of the fog machine. (See the product [Overview](#).)
3. Allow the Hurricane™ 1400 five to six minutes to heat up before continuing. (See [Fluid Tank Indicator Lights](#).)

### FC-T Wired Timer Controller Overview

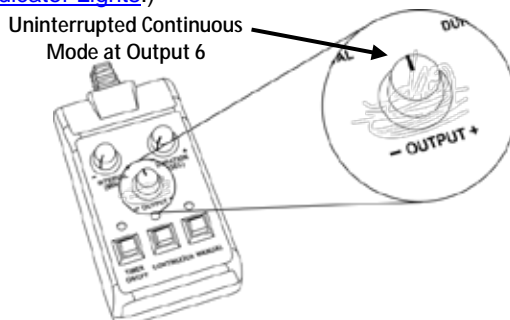

### Wired Timer Controller (FC-T) Operation Timer Mode

The FC-T wired timer controller has three modes of operation: timer, continuous, and manual.

To trigger the Hurricane™ 1400 with the timer function, follow the instructions below:

1. Set the desired output level with the **OUTPUT** knob.
2. Set the **INTERVAL** and **DURATION** knobs to the desired positions.
  - The **INTERVAL** knob sets the amount of time in between bursts of fog.
  - The **DURATION** knob sets the length of time that the fog machine will run during the burst.
3. Press the <TIMER ON/OFF> latching button. The LED indicator above the button will light up. The timer will now run as set by the **INTERVAL**, **DURATION**, and **OUTPUT** knobs.
4. Press the <TIMER ON/OFF> button again to turn off the timer.



The <MANUAL> button will override the timer.

### Continuous Mode

To trigger the Hurricane™ 1400 to continuously cycle fog, follow the instructions below:

1. Set the desired output level with the **OUTPUT** knob.
2. Press the <CONTINUOUS> latching button. The LED indicator above the button will light up. The fog machine outputs fog until the <CONTINUOUS> button is pressed again.
3. Press the <CONTINUOUS> button again to stop the fog output.



In order for Continuous mode to run uninterrupted, without the Hurricane™ 1400 stopping to reheat, set the **OUTPUT** knob no higher than 6. At Output levels above 6, the fogger will cycle through intermittent bursts of fog during its reheating program.



- The duration of Continuous fog output is based on the capacity of the tank.
- Fluid consumption will be significantly increased during Continuous mode.

### Manual Mode

To trigger the Hurricane™ 1400 manually, do the following:

1. Set the desired output level with the **OUTPUT** knob.
2. Press and hold the <MANUAL> button on the wired timer controller. The LED indicator above the button will light up. The fog machine will output fog for as long as you hold down the <MANUAL> button.
3. Release the <MANUAL> button to stop the fog output.



- The Hurricane™ 1400 unit may start producing fog intermittently to allow for fluid reheating after a period of continuous fog output. This is a normal occurrence.
- The duration of manual fog output is based on the capability of the fog machine.

---

## Optional Wireless Remote (FC-W)

The optional FC-W wireless remote allows the user to trigger the Hurricane™ 1400 to produce fog from up to 100 ft away.

1. Plug in the fog machine to power.
2. Plug the FC-W wireless remote receiver into the Wireless Remote Connector on the back of the Hurricane™ 1400. (See the product [Overview](#).)
3. Allow the Hurricane™ 1400 five to six minutes to heat up. (See [Fluid Tank Indicator Lights](#).)
4. Press and hold the <1>, <2>, <3>, or <4> button on the wireless remote. (Download the FC-W User Manual from [www.chauvetlighting.com](http://www.chauvetlighting.com) for more information on addressing the FC-W)
5. Release the button to stop the fog output.

### FC-W Wireless Remote Overview

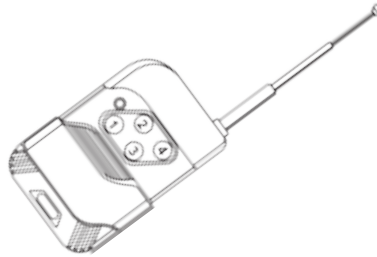

Ensure the FC-W has an unobstructed view of the receiver for maximum performance.

## Fluid Tank Indicator Lights

The Hurricane™ 1400 has indicator LEDs that light up the fluid tank to indicate the status of the product, as follows:

- Red - The heater is currently warming up.
- Flashing Red - The heater is currently warming up and no fluid is detected.
- Blue - The heater is ready to produce fog.
- Flashing Blue - The heater is ready to produce fog and no fluid is detected.

---

## 5. TECHNICAL INFORMATION

### Fogger Maintenance

Do not allow the fogger to become clogged. After every 40 hours of continuous operation, use CHAUVET® Fog Cleaner Quart (FCQ) through the system to prevent the accumulation of particulate matter in the heating element.

The recommended cleaning procedure is as follows.

1. Unplug the product from power.
2. Empty all fog fluid from the machine.
3. Add cleaning solution (FCQ) to the tank.
4. Connect the product to power and allow it to warm up.
5. Run the unit in a well-ventilated area until the tank is almost empty. **Do not allow the pump to run dry.**
6. Refill with fogger fluid to continue using the fogger. Run the machine briefly to clear any remaining cleaning solution from the pump and heater.



**Do Not operate the machine without fluid at any time.**



**Fog Cleaner Quart (FCQ) was specifically developed by Chauvet to clean your Hurricane™ 1400. Make sure you use FCQ regularly, no longer than 90 days between cleanings, to increase the life of your product.**

### Storage

Before storing the fogger, run FCQ through the system as described in the cleaning procedure above; however, only follow steps 1 through 5. **Do not refill the tank with fog fluid if storing the fogger.** Cleaning the system prior to storage will help prevent any particles from condensing inside the pump or heater while not in use.



**Test-run your Hurricane™ 1400 on a monthly basis to achieve the best performance.**

## 6. GENERAL TROUBLESHOOTING

Symptom	Indicator Status	Possible Cause	Possible Action
No output or short output	Red	Heater warming up	Allow the product to warm up completely. This should take less than 10 minutes.
	Red flashing	Air bubble in fluid line	Allow the product to warm up completely.
			Turn fog machine 45° to flatten out the bubble and allow the fog fluid to flow properly
			Turn off the product for 5 seconds, and then turn it back on. Repeat as necessary. After more than 10 attempts, contact Customer Service.
	Blue	Incorrect fluid	Clean thoroughly with CHAUVET® FCQ. For full instructions, see <a href="#">Fogger Maintenance</a> . Refill with CHAUVET® water-based fog fluid.
		Blocked pipes	Contact Customer Service
Failing part		Contact Customer Service	
Spitting fluid	Blue blinking	Incorrect fluid	Clean thoroughly with CHAUVET® FCQ. For full instructions, see <a href="#">Fogger Maintenance</a> . Refill with CHAUVET® water-based fog fluid.
		Blocked pipes	Contact Customer Service
		Failing part	Contact Customer Service
	Blue	Incorrect fluid	Clean thoroughly with CHAUVET® FCQ. For full instructions, see <a href="#">Fogger Maintenance</a> . Refill with CHAUVET® water-based fog fluid.
		Blocked pipes	Contact Customer Service
		Failing part	Contact Customer Service
Normal	Blue	Normal	Normal function
Circuit breaker or fuse keeps blowing	N/A	Excessive load on the circuit	Make sure that the total load does not exceed the recommended capacity of the breaker or fuse's nominal current
Product does not power up		Short circuit along the power lines	Check the power lines and power cords
		No energy on power outlet	Check power outlet Change to another outlet
		Loose or damaged power cord	Check the power cord
		Blown fuse	Replace blown fuse with a good one of the same type and rating
		Internal problem	Send product for repair
Product does not respond to DMX	Blue	Wrong starting address on the product	Set the correct starting address on the product
		Wrong polarity setting on the DMX controller	Change the signal polarity on the controller
		Loose or damaged DMX cable	Check the DMX cable entering the faulty unit
		Internal problem	Send product for repair
Intermittent DMX Problems		Signal cables are not DMX compatible	Replace non-DMX cables with true DMX cables
		Interference with AC or radio signals	Keep DMX cables away from AC wires or radio equipment
		DMX cable too long	Use a shorter DMX cable or install an optically coupled DMX amplifier right before the product with intermittent problems
		Terminator not connected	Install a terminator
False Sensor Reading (Priming)	Red	Air bubbles in fluid line	Fill the tank. Allow the unit to reach the normal operating temperature and for the blue indicator to light. Set the output to the highest level. Power cycle the unit 1-2 times until the fluid reaches the sensor. The blue tank indicator light stops flashing.
			Fill the tank. While the unit is operating, pinch the fluid line between your thumb and forefinger, and hold for 3 to 5 seconds creating a vacuum in the system. Release the pinched portion and allow the fluid to flow naturally.
			Fill the tank. While the unit is operating; remove but do not disconnect the fluid tank and tilt the machine at a 45° angle.
	Red	Empty fluid tank	Refill tank with the correct CHAUVET® water-based fog fluid



If you still experience problems after trying the solutions presented here, contact Chauvet Technical Support.

# 7. TECHNICAL SPECIFICATIONS

<b>Dimensions and Weight</b>	<b>Length</b>	<b>Width</b>	<b>Height</b>	<b>Weight</b>
	14.2 in (360 mm)	10.1 in (256 mm)	9.3 in (235 mm)	10.2 lb (4.7 kg)
<b>Note:</b> Dimensions in inches rounded to the nearest decimal digit.				
<b>Power</b>	<b>Power Supply Type</b>	<b>Range</b>		<b>Voltage Selection</b>
	Model-specific	120 VAC, 60 Hz or 230 VAC, 50 Hz		Fixed
	<b>Parameter</b>	<b>120 V, 60 Hz</b>		<b>230 V, 50 Hz</b>
	Consumption	1,530 W		1,530 W
	Operating current	12.4 A		6.6 A
	Fuse	F 15 A, 250 V		F 15 A, 250 V
<b>Operation</b>	<b>Power I/O</b>	<b>US/Worldwide</b>		<b>UK/Europe</b>
	Power input connector	Hard-wired		Hard-wired
	Power Cord	Edison (US)		Local plug
	<b>Heat-up Time</b>	<b>Tank Capacity</b>		<b>Fluid Consumption</b>
	3 min	0.5 gal (2 l)		100 ml/min
<b>Fog Output</b>	<b>Output</b>			
	21,500 cfm			
<b>Thermal</b>	<b>Maximum External Temp.</b>	<b>Cooling System</b>		
	104 °F (40 °C)	Convection		
<b>Ordering</b>	<b>Product Name</b>	<b>Item Code</b>	<b>UPC Number</b>	
	Hurricane™ 1400 (120 V)	09071108	781462214562	
	Hurricane™ 1400 (230 V)	09071109	781462214579	



---

# RETURNS

In case you need to get support or return a product:

- If you are located in the U.S., contact Chauvet World Headquarters.
- If you are located in the UK or Ireland, contact Chauvet Europe Ltd.
- If you are located in Mexico, contact Chauvet Mexico.
- If you are located in Benelux, contact Chauvet Europe BVBA.
- If you are located in any other country, DO NOT contact Chauvet. Instead, contact your local distributor. See [www.chauvetlighting.com](http://www.chauvetlighting.com) for distributors outside the U.S., UK, Ireland, Mexico, or Benelux.



**If you are located outside the U.S., UK, Ireland, Mexico, or Benelux, contact your distributor of record and follow their instructions on how to return Chauvet products to them. Visit our website [www.chauvetlighting.com](http://www.chauvetlighting.com) for contact details.**

Call the corresponding Chauvet Technical Support office and request a Return Merchandise Authorization (RMA) number before shipping the product. Be prepared to provide the model number, serial number, and a brief description of the cause for the return.

Send the merchandise prepaid, in its original box, and with its original packing and accessories. Chauvet will not issue call tags.

Clearly label the package with the RMA number. Chauvet will refuse any product returned without an RMA number.



**Write the RMA number on a properly affixed label. DO NOT write the RMA number directly on the box.**

Before sending the product, clearly write the following information on a piece of paper and place it inside the box:

- Your name
- Your address
- Your phone number
- RMA number
- A brief description of the problem

Be sure to pack the product properly. Any shipping damage resulting from inadequate packaging will be your responsibility. FedEx packing or double-boxing are recommended.



**Chauvet reserves the right to use its own discretion to repair or replace returned product(s).**

---

## CONTACT US

### WORLD HEADQUARTERS - Chauvet

#### General Information

Address: 5200 NW 108<sup>th</sup> Avenue  
Sunrise, FL 33351  
Voice: (954) 577-4455  
Fax: (954) 929-5560  
Toll free: (800) 762-1084

#### Technical Support

Voice: (954) 577-4455 (Press 4)  
Fax: (954) 756-8015  
Email: [tech@chauvetlighting.com](mailto:tech@chauvetlighting.com)

World Wide Web [www.chauvetlighting.com](http://www.chauvetlighting.com)

### UNITED KINGDOM AND IRELAND - Chauvet Europe Ltd.

#### General Information

Address: Unit 1C  
Brookhill Road Industrial Estate  
Pinxton, Nottingham, UK  
NG16 6NT  
Voice: +44 (0)1773 511115  
Fax: +44 (0)1773 511110

#### Technical Support

Email: [uktech@chauvetlighting.com](mailto:uktech@chauvetlighting.com)

World Wide Web [www.chauvetlighting.co.uk](http://www.chauvetlighting.co.uk)

### MEXICO - Chauvet Mexico

#### General Information

Address: Av. Santa Ana 30  
Parque Industrial Lerma  
Lerma, Mexico C.P. 52000  
Voice: +52 (728) 285-5000

#### Technical Support

Email: [servicio@chauvet.com.mx](mailto:servicio@chauvet.com.mx)

World Wide Web [www.chauvet.com.mx](http://www.chauvet.com.mx)

### CHAUVET EUROPE - Chauvet Europe BVBA

#### General Information

Address: Stokstraat 18  
9770 Kruishoutem  
Belgium  
Voice: +32 9 388 93 97

#### Technical Support

Email: [Eutech@chauvetlighting.eu](mailto:Eutech@chauvetlighting.eu)

World Wide Web [www.chauvetlighting.eu](http://www.chauvetlighting.eu)

Outside the U.S., United Kingdom, Ireland, Mexico, or Benelux contact your dealer. Follow their instructions to request support or to return a product. Visit our website for contact details.