

**If your instrument has a selection switch:**

Shown at the right is the EMG B245 Pickup Buss which is used for instruments that have 2 pickups and a 3 position selection switch. If you have a selection switch and want your installation to remain solderless, you'll need a B245 Buss. Either send an e-mail to: [sales@emgpickups.com](mailto:sales@emgpickups.com) or call: 800 821-1446 to get the buss.

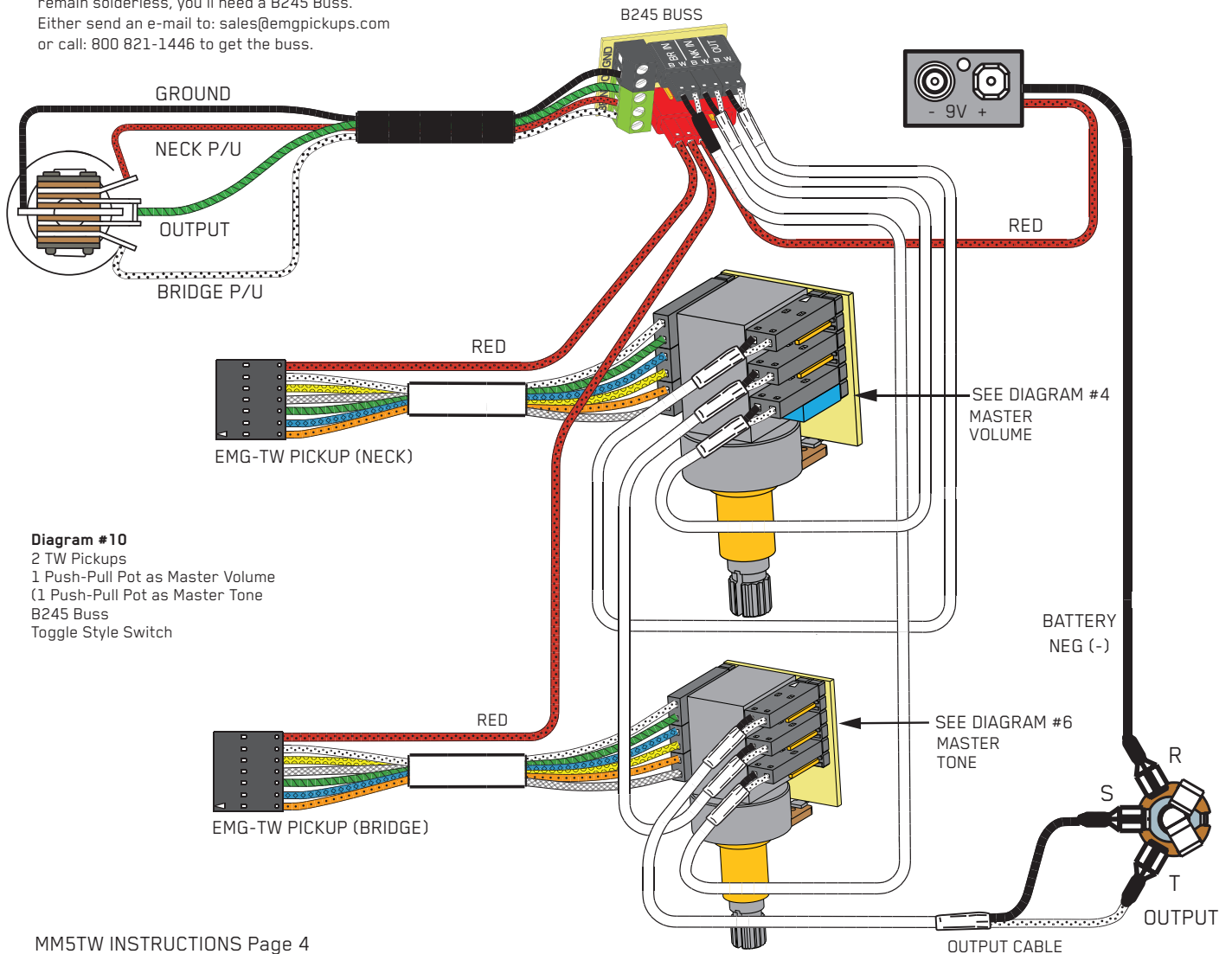

**Diagram #10**  
2 TW Pickups  
1 Push-Pull Pot as Master Volume  
(1 Push-Pull Pot as Master Tone  
B245 Buss  
Toggle Style Switch



0230-0186r-B

PO BOX 4394  
SANTA ROSA, CA  
95402 USA

P (707) 525-9941  
F (707) 575-7046  
EMGPICKUPS.COM

## INSTALLATION INFORMATION

### EMG MODEL: MM5TW

MAXIMUM RECOMMENDED STRING WIDTH 3.08" (78.23)

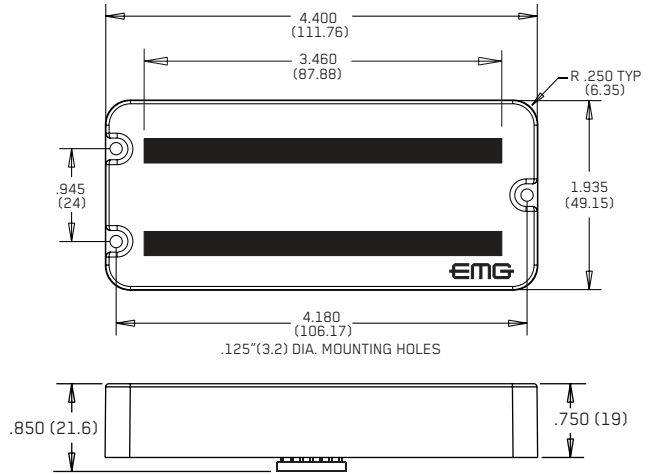

### SPECIFICATIONS:

Logo Color  
Magnet Type\*  
Resonant Frequency (KHz)  
Output Voltage (String)  
Output Voltage (Strum)  
Output Noise (60 Hz)  
Output Impedance (Kohm)  
Current @9V (Microamps)  
Battery Life (Hours)  
Maximum Supply (Volts DC)  
\* Magnet Type CS (Ceramic and Steel)

### MODEL:

MM5TW  
Copper  
C/S

Single-Coil

Dual-Coil

EMG-MM5TW (SIDE VIEW)

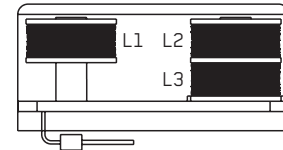

In Dual-coil mode, coils L1 and L2 are active.  
In Single-coil mode, coils L2 and L3 are active.

### INSTALLATION NOTES:

The EMG-MM5TW has a variety of ways it can be wired into a bass. The diagrams included are limited to the most popular because of space. The addition of the plug-on PC Board on the Push-Pull Pot adds further flexibility as you will see in the diagrams. We suggest you look fully at the installation diagrams included in this sheet along with the B245 Pickup Buss data sheet included in this package before beginning your installation. The Push-Pull Pot allows you 2 options as a volume control and 2 other options using the pot as a tone control. If you don't see a diagram that fits your instrument directly, or you want to do something completely different, contact our technical department and we'll create a diagram you can follow for your installation. Certain limitations apply...

### INCLUDED WITH EACH PICKUP:

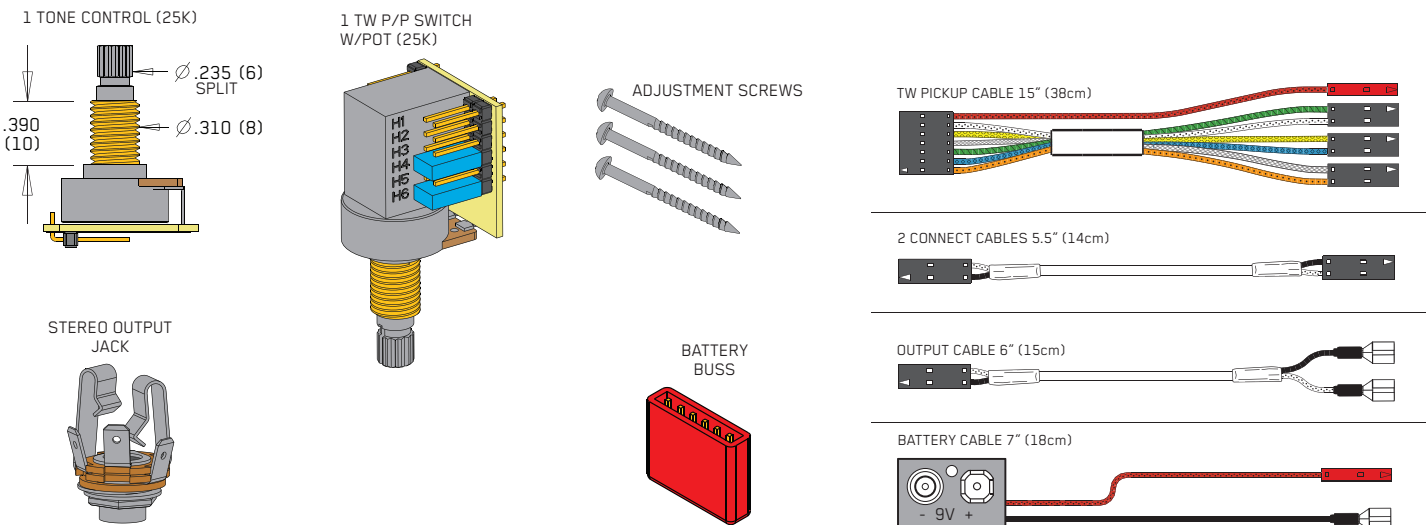

### WARRANTY

All EMG Pickups and accessories are warranted for a period of two years. This warranty does not cover failure due to improper installation, abuse or damage. If upon examination the pickup is determined to be defective, a replacement will be made. Warranty replacement products are covered by this same warranty. This warranty covers only those pickups and accessories sold by authorized EMG Dealers. This warranty is not transferable.

**General Notes:**

Every attempt has been made to make this a solderless installation. There are some instances where this is not possible;

- 1) If your instrument uses the long panel output jack and you had passive pickups you will need a new stereo output jack, the Switchcraft 152B is recommended. Soldering to the new jack will be required.
- 2) Some instruments may already have a battery holder installed, in that case soldering may be required.
- 3) Instruments with two pickups may need soldering to the selection switch in some installations.

**Using the TW Push-Pull Switch**

The Push-Pull Switch included with the EMG-TW allows you to choose between two internal pickups of the EMG-TW, single-coil and dual-coil. The Push-Pull Pot has two separate sections: The Switch and the pot, described below.

Refer to Diagrams #1 and #2

The Push-Pull Switch section (DPDT) lets you choose between the single-coil sound and a dual-coil sound by pulling or pushing the pot shaft up or down. You have the option of having the single-coil sound in either the up or down position and vice-versa for the dual-coil sound.

Diagrams #1 and #2 show how to connect the TW Pickup cable to choose either option. Select the diagram that suits you and push the cable connectors onto the single line 6-pin header.

Simply turn over cable connectors 1 and 2 to change the wire order and this will choose between the two options.

Connector 3 remains the same for either choice.

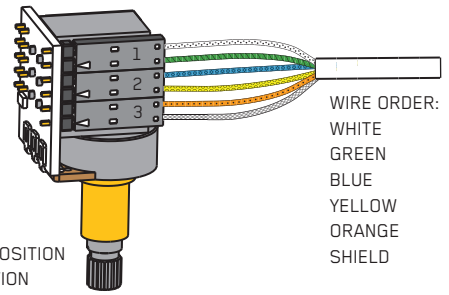

**Diagram #1**  
HUMBUCKING ON: DOWN POSITION  
SINGLE COIL ON: UP POSITION

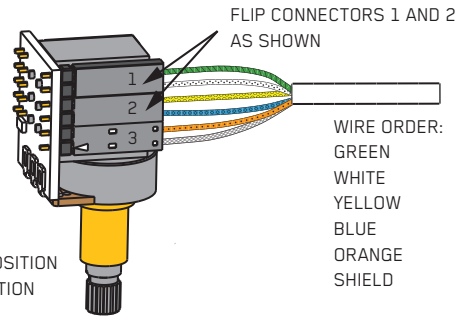

**Diagram #2**  
SINGLE-COIL ON: DOWN POSITION  
HUMBUCKING ON: UP POSITION

**Diagram #3**

PUSH / PULL POT USED AS THE PICKUP VOLUME CONTROL

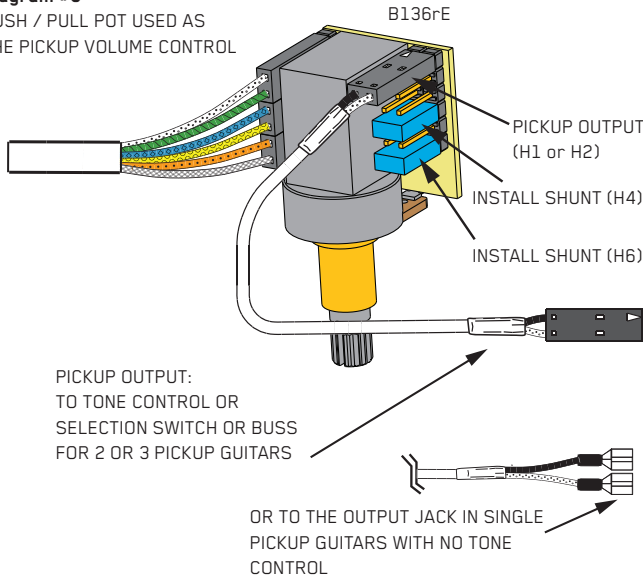

**Using the TW Push-Pull Pot Section**

The Push-Pull Pot side of the EMG-TW allows you 4 different options:

- 1) Use the pot as a Master Volume for the Instrument
- 2) Use the pot as a Volume control for the TW Pickup
- 3) Use the pot as a Master Tone control for the Instrument
- 4) Use the pot as a Tone control for the TW pickup

On the PC Board there is a dual-line header with 6 pairs of pins. They are listed on the PC Board as H1 through H6. By using the the connections shown in Diagrams #3 through #6, you can choose any of the 4 options.

**Using the Pot Section as:**

**1) The Pickup Volume control, or a Master Volume for the Instrument.**

**Refer to Diagrams #3 and #4**

The pot section (25KA) can be used either as a Volume control for the pickup or, it can be used as the Master Volume for the guitar. Diagrams #3 and #4 show how to connect either option.

Use the dual-line 12-pin header and push the cables on and install the shunts as needed onto the labeled headers H1 thru H6.

Use Diagram #3 if you have a single TW installed in your instrument, or have two or more pickups in your instrument and want to use the pot as the Volume control for the TW Pickup only.

Installing the shunts on positions H4 and H6 sends the pickup signal to the wiper of the 25K Pot, and the output of the 25K Pot is at position H1 or H2.

Diagram #4 allows you to use the 25K Pot independently of the pickup output. By taking the output of the pickup from position H5, the Volume control is now available to use as a Master Volume with H1 or H2 being the input to the Volume control. H1 and H2 positions are interchangeable. Position H5, now the output of the pickup, would typically go to a selection switch or a pan-pot. Don't forget to install the shunt on H6.

**Diagram #4**

PUSH / PULL POT USED AS THE MASTER VOLUME CONTROL

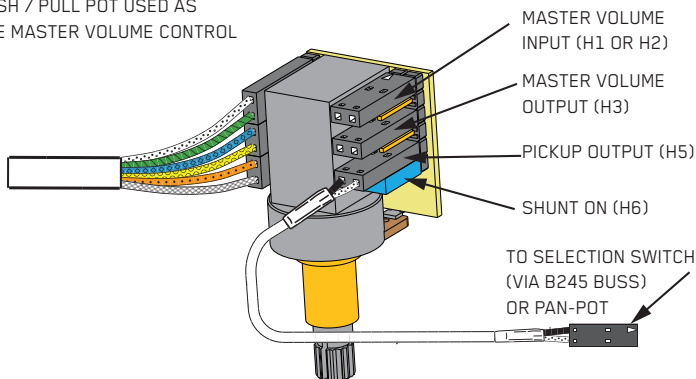

**Diagram #5**  
PP POT USED AS THE PICKUP  
TONE CONTROL

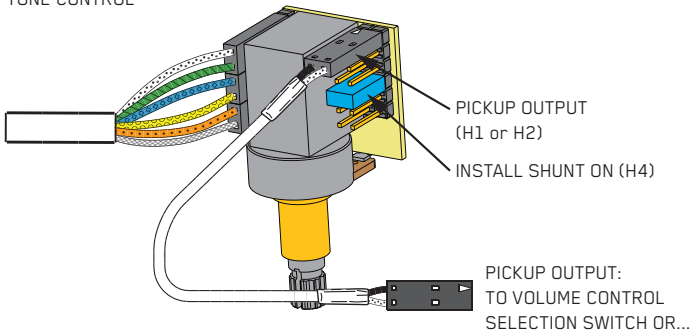

**Diagram #6**  
PUSH-PULL POT USED AS A MASTER  
TONE CONTROL

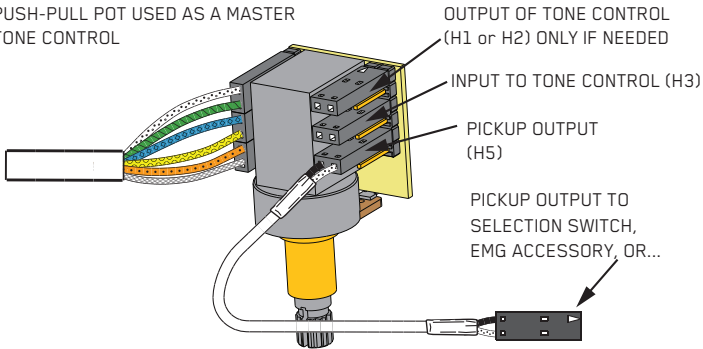

**Diagram #7**  
Insert the plug onto the 7 pin header  
of the pickup as shown here.  
Note the orientation arrow.

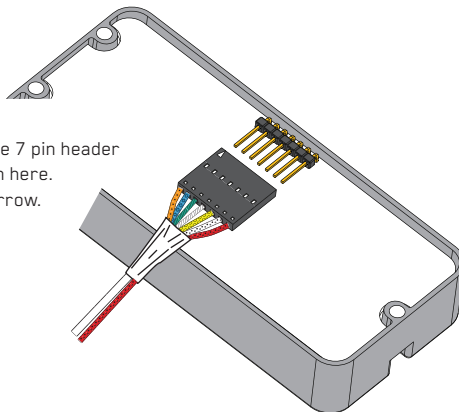

**Diagram #8**  
One TW Pickup  
Master Volume and Tone Control

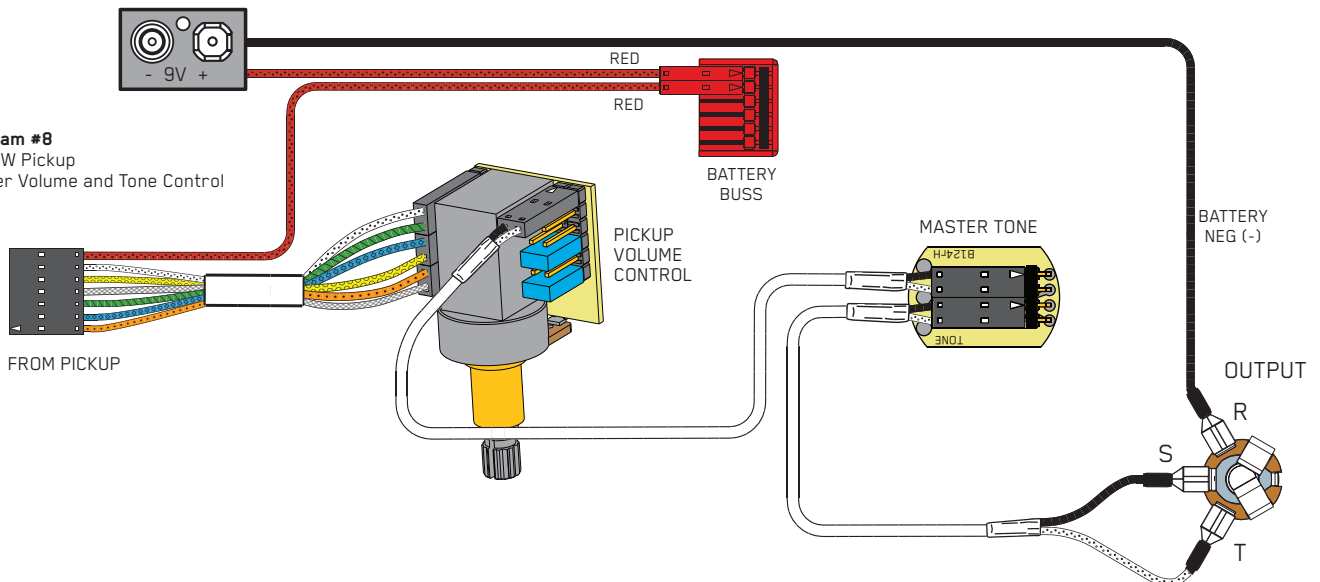

- \*\*\*\*Tips and Tricks\*\*\*\* Start your installation by:**
- 1) Determine which type output jack your instrument has.  
A Stereo 12B type is Included, but if you have a long panel jack a SwitchCraft 152B Long Panel Jack will be required.
  - 2) Remove the strings, remove any existing Pickups and controls (remember the order and function of each control)
  - 3) Determine a good spot for the Pickup Buss and make sure the cable or wires from the selection switch will reach the Pickup Buss,
  - 4) Install the EMG Volume and Tone Controls and tighten them in.
  - 5) Then install the pickups keeping any excess cable under the pickup rather than in the control cavity.
  - 6) IMPORTANT: EMG Active pickups do not require a string ground wire! DO NOT Reconnect the string ground, it is unnecessary.

**Using the Pot Section as:**  
2) The Pickup Tone control or as a Master Tone control for the instrument.  
Refer to Diagrams #5 and #6

The pot section (25KA) can be used either as a Tone control for the pickup or it can be used as a Master Tone control for the guitar. Diagrams #5 and #6 show how to connect either option. Use the dual-line header, push the cables on and install the shunts as needed onto headers H1 thru H6.

Use Diagram #5 if you have a single TW installed in your instrument, or have two or more pickups in your instrument and want to use the pot as the Tone control for the TW Pickup only. Installing the shunt on position H4 connects a tone capacitor on the PC Board to the wiper of the 25K Pot and creates a passive Tone control. The output of pickup can be either position H1 or H2.

Diagram #6 uses the 25K Tone control independently of the pickup output. By taking the output of the pickup from Position H5, the control is now available to use as a Tone Control independent of the pickup output. Position H3 is the input to the Tone Control, with H1 or H2 being the output of the control, if necessary. Position H5, the output of the pickup, would typically go to a selection switch or output jack.